

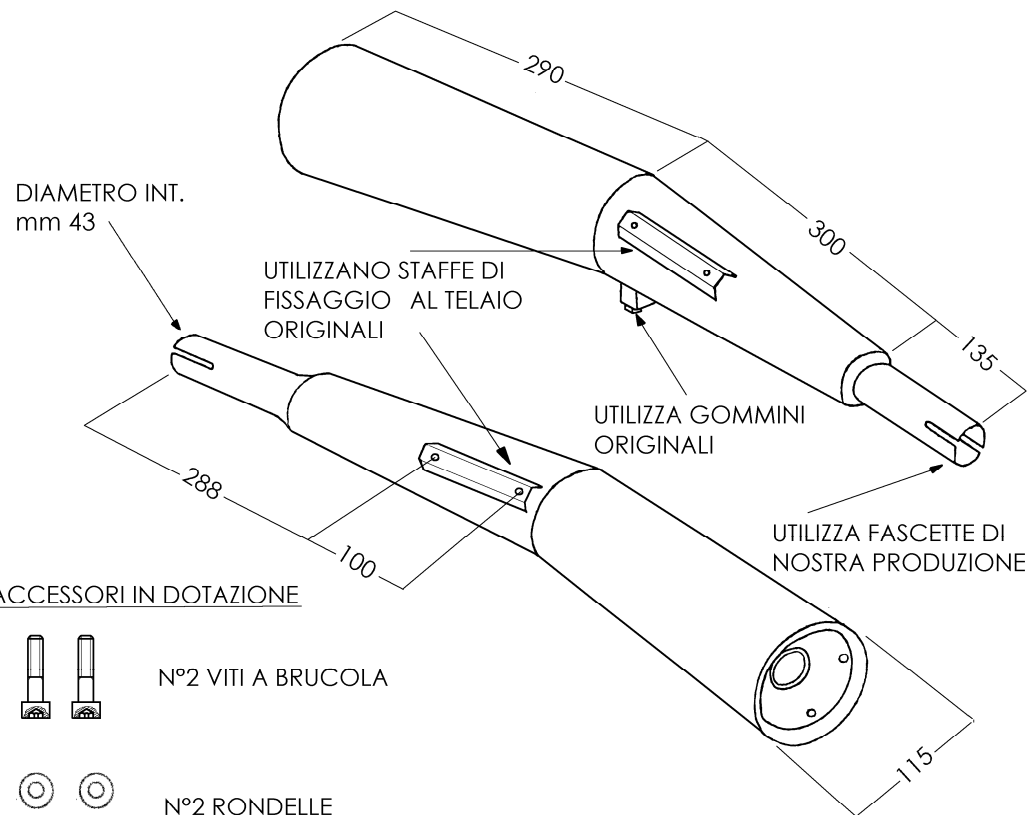

HONDA CB 900F '82/1100F

ARTICOLO COMMERCIALE:
H/2009/NC
COPPIE MARMITTE
AFTER MARKET
CROMATO NERO
OMOLOGAZIONE
E1 29009



ACCESSORI IN DOTAZIONE



N°2 VITI A BRUCOLA



N°2 RONDELLE

N° 2 M6



N° 2 FASCETTE DIAM. mm