

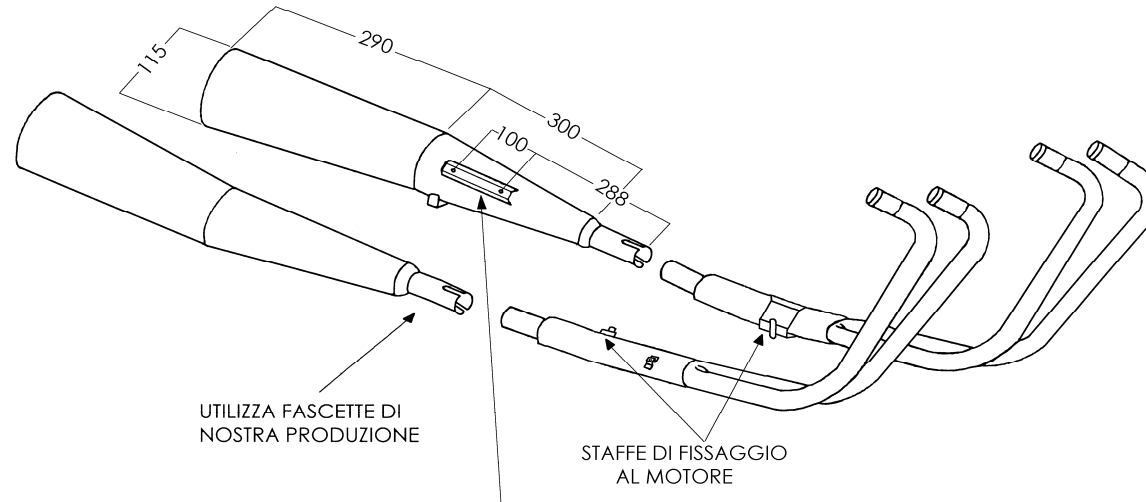

# HONDA CB 900F 82/CB 1100F

ARTICOLO COMMERCIALE: H/5006/NC
GRUPPO COMPLETO
CROMATO NERO



ACCESSORI IN DOTAZIONE

UTILIZZA STAFFE DI FISSAGGIO AL TELAIO ORIGINALI



N° 2 VITI A BRUCOLA



N° 2 RONDELLE



N° 2 FASCETTE  
DIAM. mm 48